

### Step 1

將機芯對準底板背面圖示

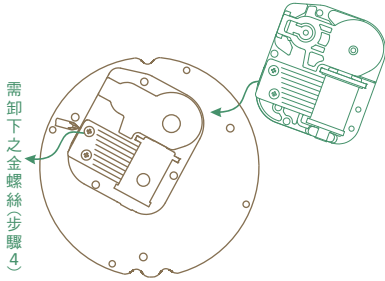

### Step 2

(1) 翻面將螺絲A依圖示位置上緊固定 (2) 將螺絲C(短)依圖示位置上緊固定

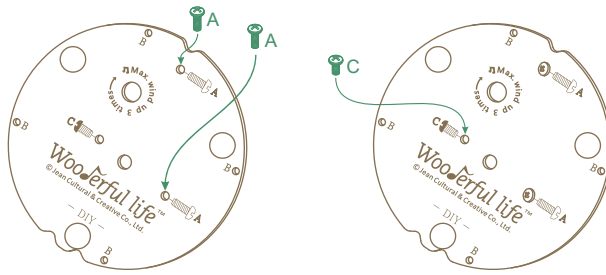

### Step 3

將發條轉鍵順時針方向旋緊

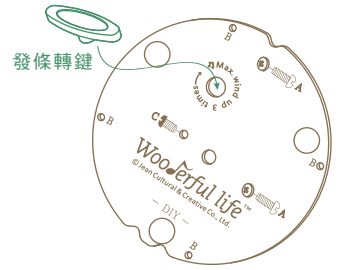

### Step 4

將機芯上面的金色螺絲卸下  
\*右邊銀色螺絲切勿鬆開

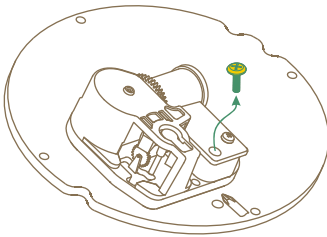

### Step 5

將黑螺絲F由支架側面橫放入B孔位暫放，待步驟7繼續操作

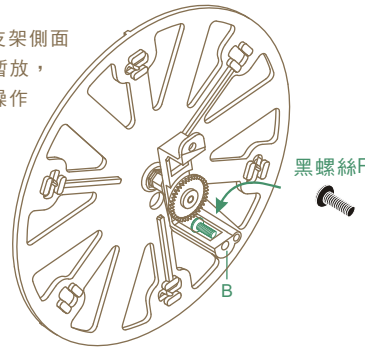

支架示意圖

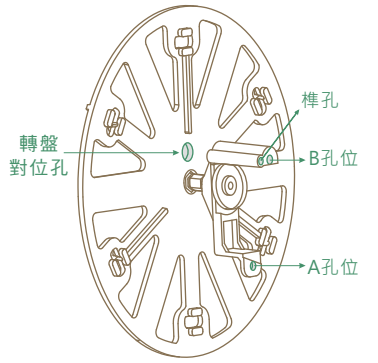

### Step 6

對應繞圈零件數量

繞圈轉盤已內含磁鐵1個

可再加購1個磁鐵  
黏貼於原有磁鐵的對角線位置

★ 轉盤對孔位

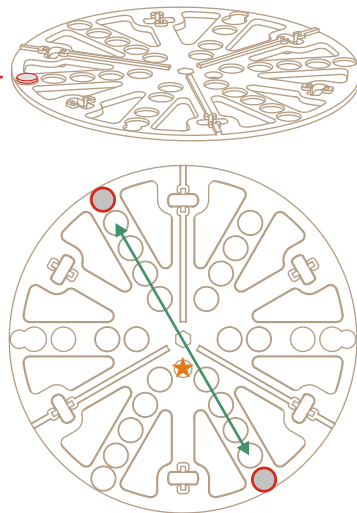

### Step 7

將支架榫孔按入機芯榫位

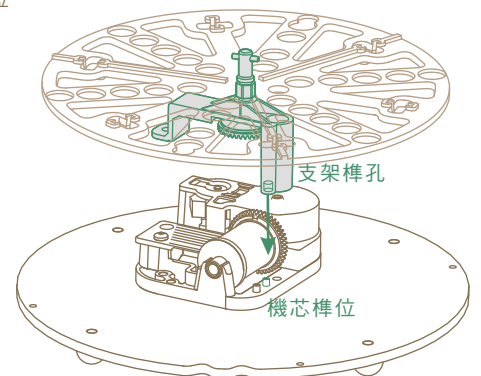

### Step 8

確認支架齒輪與機芯齒輪  
確實咬合，在A孔位鎖回金螺絲

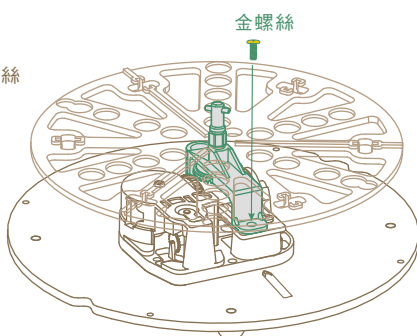

### Step 9

為避免支架齒輪與機芯齒輪互相卡住  
請先將轉盤稍微上提  
再將轉盤對位孔旋轉對準B孔位  
最後將黑螺絲F鎖緊

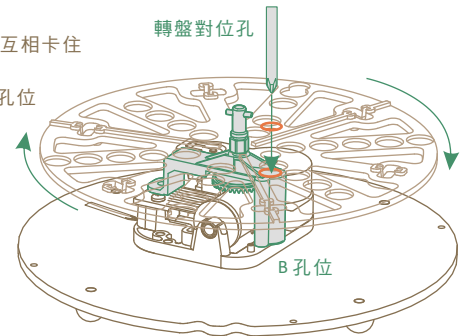

### Step 10

底盤齒輪與底座齒輪確實咬合

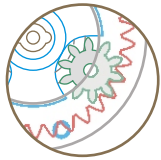

齒輪咬合

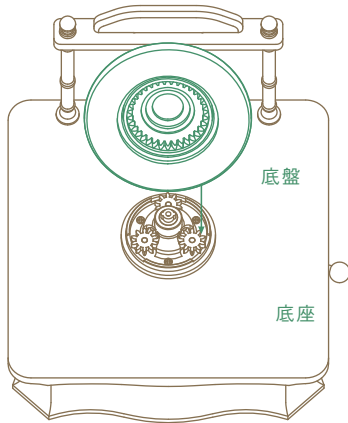

### Step 11

頂端平台對準套筒

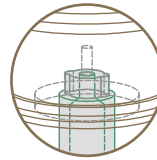

與中柱咬合

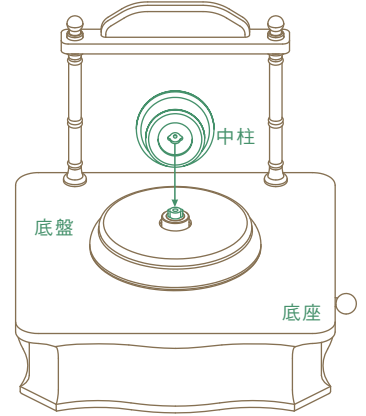

### Step 12

中柱和底盤與底座結合後  
將包裝附的金色螺絲放入套筒

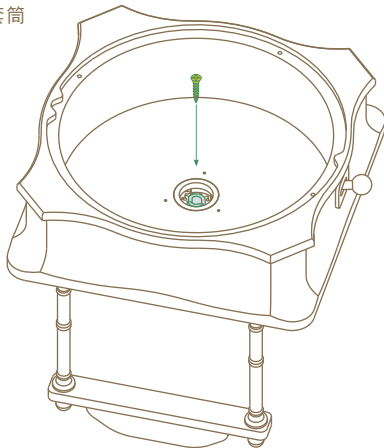

### Step 13

芯棒插銷設定好方向  
卡入軸接套筒的底部凹槽  
左右旋轉中柱使芯棒對上軸接套筒槽

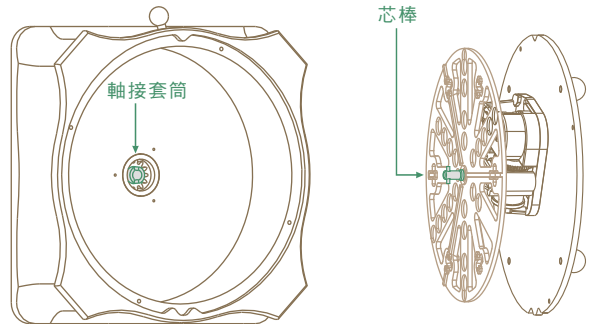

### Step 14

依對位凹凸點將底板扣入底座，  
鎖上螺絲B(金色尖頭)

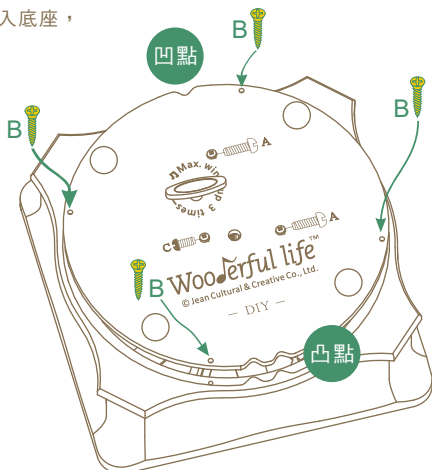

### Step 15

安裝完成後，  
即可開始裝飾零件

